



PENSANDO EM TROCAR DE CARRO? DESCUBRA O PREÇO CERTO. VER PREÇO KBB

Home > News > Advice

SHARE  

The 3 pillars of low fuel consumption - What gives you a car that is more efficient

10-04-2018 13h00 by KBB - Gustavo Henrique Ruffo

Aerodynamics, mass and powertrain are the main elements to tackle in order to reduce emissions and help save on fuel

Weight reduction in the Audi A4 Sedan

Important details
09/15

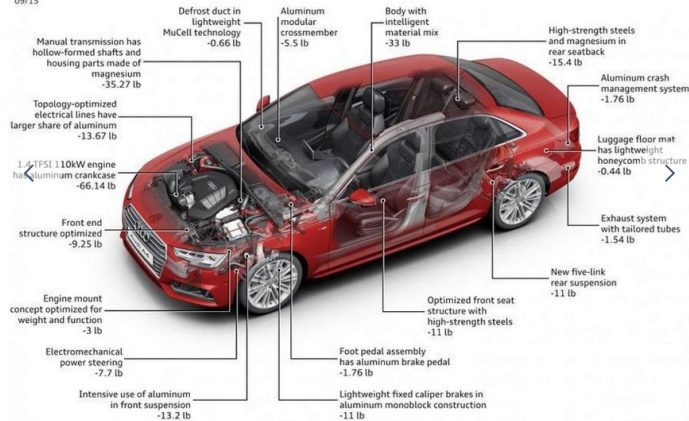

Current times are requiring ever smaller emissions levels for car manufacturers. **A demand that even threatens the existence of the large-scale combustion engine** as we know it today. Not only from consumers, but mainly from more restrictive laws. Faced with this scenario, there are three main elements tackled by automakers for cars to be more frugal on fuel consumption: aerodynamics, mass (or weight, if you prefer) and powertrain. The more aerodynamic and lighter a car is, the more efficient its engine is, the less the driver of the vehicle in question will spend to refuel. All that with the industry rationale of getting the most out of the lowest possible cost. Do you have any idea on the amount of work required to take care of each of these pillars of fuel saving? Or how much it costs? We can tell you ...

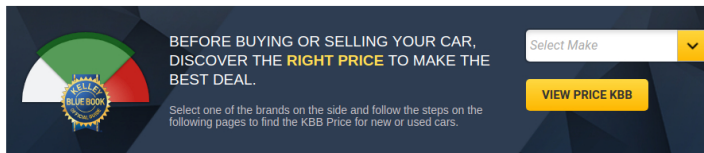

BEFORE BUYING OR SELLING YOUR CAR, DISCOVER THE RIGHT PRICE TO MAKE THE BEST DEAL. VIEW PRICE KBB

Of all these elements, the more effective is the improvement of the engine and of the transmission. According to a study by Greg Pannone, from Controltec, for the California Air Resources Board (CARB), if all of the engines in the California fleet were to meet the most efficient standards available today, this would allow a 10 g reduction of carbon dioxide per mile traveled from a total of 27 g/mile possible reduction. It represents the biggest part of the total possible reduction, which would also require changes in tire rolling resistance, aerodynamics and weight reduction. But engines are also the most expensive elements of an automobile. A clear evidence of this are the engine families that, with some technological improvements, are still or were in production for decades. **Ford's Endura E engine, used by the first Ford Ka, was in fact a Kent engine, which was introduced with the Anglia in 1959.** The GM Family 1 engine used currently by the Chevrolet Onix and Sonic, among others, was born in 1982. "Powertrains have a high cost for changes and the amount of time to pay for them is long. Amortization requires more time", said professor Francisco Nigro, member of the Superior Council of SAE Brasil (Society of Automotive Engineers).

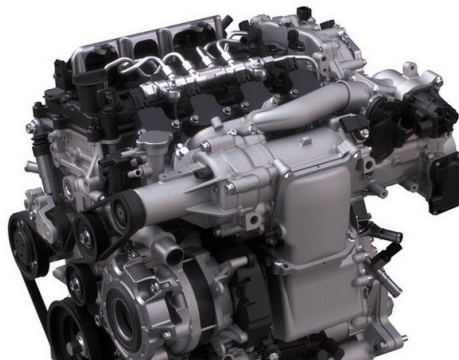

DESCUBRA O PREÇO PARA VOCÊ COMPRAR SEU CARRO OKM. VER PREÇO KBB

Find the Price of your New or Used Car



Hatchback

Sedan



SUV/Crossover

Pickup



Wagon

Van/Minivan



Coupe

Convertible



Hybrid/Electric

Luxury



DESCUBRA O PREÇO PARA VOCÊ COMPRAR SEU CARRO OKM. VER PREÇO KBB



Considering the recent developments in combustion engines, such as **Infiniti's variable compression ratio, VC-Turbo**, and **Mazda's SPCCI cycle, applied to the SKYACTIV-X engine**, it would be enough to adopt all available technologies in a single engine. The problem is that the bill does not add up. "Cars are born of a queuing of technologies. They are put together according to the goals you want to achieve, the target audience and the cost-effectiveness of each", says Nigro. Technically, a small engine could perfectly have the technologies we've mentioned plus direct injection, turbocharger and even valve systems that eliminate the throttle body and current camshafts, such as the **Freevalve developed by Koenigsegg**. Financially, however, it would not be feasible.



As much as the combustion engines show improvements over time, they are very unlikely to be as clean or efficient as the electric ones already are. Why, then, doesn't the automotive industry adopt them once and for all? Because of their investment history. "When I make an investment, I have to ensure that it will last long enough to pay off. If something comes up that eliminates the need for what I produce, I lose that investment", explains the professor. In other words, car manufacturers have put a load of money into engine plants and new technologies and have only been able to make them more accessible by the large scale of production. If they started using electric motors all of a sudden, what would these projects and factories do? "Check what Toyota did. **Everyone knows there's no way to beat the efficiency of an electric car**, but the batteries are expensive, the control systems are expensive, the motors... So Toyota created a hybrid car, with a design that would appeal to the public concerned with the environment, to increase the scale of many of these components. Using the combustion engine, it began to make the electric cars a real possibility", says Nigro. This investment history is something that people who have never worked in this industry before, such as Tesla, or who want to get into it, like Dyson and **HK**, do not have. And that gives them a major competitive advantage. If it were not for this liability, it is quite possible that the automotive industry would be already ahead in the race for the electric car, a more efficient and cleaner solution than the ones that need a combustion engine.

Mass reduction

The second most important source of emission reduction and fuel saving is mass reduction. According to a study by the **VTT Technical Research Center in Finland**, a 10% lighter car would deliver fuel savings of 6% to 7% compared to a similar but heavier one. It is from this effort that, to a large extent, **the downsizing of the engines** has emerged. To have smaller and lighter engines with a performance that was only extracted from bigger machinery helps save on mass. Or 3-cylinder engines instead of 4, even if they have the same displacement. Include in this effort the use of multiplexed systems, with multiple ECU (electronic control units), something that has reduced the amount of wiring needed in automobiles to control their various analogue-age equipments. Or the use of suspension parts and other pieces of aluminium, magnesium and carbon fiber. Here, the cost is also high, because of the noble materials, but the reduction targets can also be met with rethought components, such as the ones presented by the **Edson 2, the ultralight car**. According to those involved in the project, there are pieces that can weigh 1/10 of the conventional ones, without loss of resistance or any other sort of vulnerability, only with a new design.

Weight-optimised mix of metals

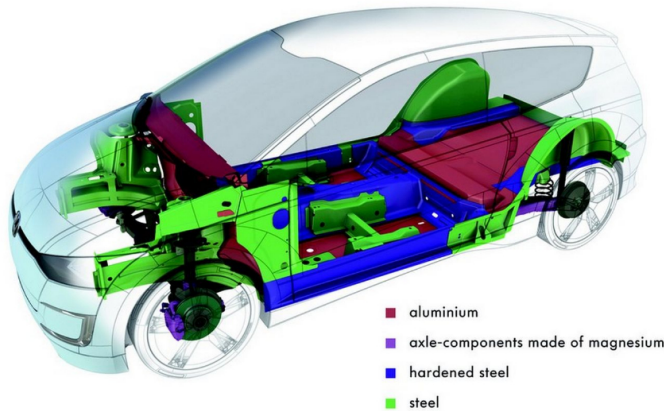

The advantages of a lighter car are many. As the engine has to make less effort to move it, it does not have to be very powerful. And the energy (or fuel) spent in the process is reduced. A vehicle with less mass is also safer, since the structure has to absorb less kinetic energy in the event of an accident. The dynamics also tend to improve, with a lower center of mass, more agile accelerations, smaller braking distances and a more balanced weight distribution between the axles. BMW, with its new **modular CLAR platform, applies the Carbon Core technology to the 7 Series with carbon fiber components**. Audi already had models with bodies made entirely of aluminium, such as the A2 and the A8. Mazda is considering replacing all lead-acid batteries in their cars with much lighter lithium-ion units. Even Ford uses aluminium bodywork on the F-150 and **made a Fusion/Mondeo that weighed the same as a Fiesta, the Lightweight Study**.





The problem of lighter materials, again, is cost. "Weight is something very expensive to reduce", says the professor. In a recent lecture, Nigro presented data from an ICCT (International Council on Clean Transportation) study that shows that a mass reduction of around 5% adds a little more than US\$ 1,000 to the total cost of the vehicle. If the reduction is set to 10%, the cost goes up to something close to US\$ 2,000. If the objective is 20%, the increase is more than US\$ 3,000. Check these numbers on the graphic below or at the [study itself, at the ICCT website](#).

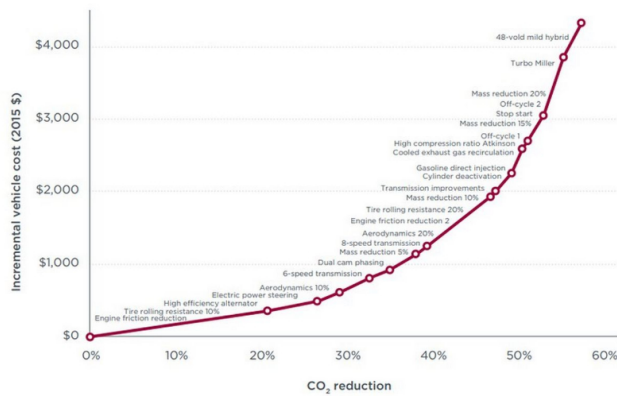

Figure 2. Lowest cost efficiency technology progression for CO₂ reduction in passenger cars and crossover vehicles (Based on U.S. EPA, 2016c).

As you can see, the technologies adopted first are those that add the least cost to the vehicle. "Green tire with low rolling resistance is a low investment measure. This is why you see so many manufacturers using this kind of tire," says Nigro. Transmissions with more speeds also have a beneficial effect on reducing emissions. Hence the 10-speed transmissions that are now on the [Ford Mustang](#) and the [Chevrolet Camaro](#), for example.

Less air resistance

The final frontier of efficiency in consumption is aerodynamics. But it does have an impact: it is only felt at higher speeds, in which the resistance of the air requires a much greater energy amount to be beaten. Something that does not hinder it from being constantly improved. When it was first released, in 1988, the Opel Vectra impressed the world with an aerodynamic coefficient of 0.28. The Mercedes-Benz CLA recently took that number to 0.22. And it was not the best model of the brand in this matter. The Bionic Car concept, shown in 2005, reached an incredible cx of 0.19. With a different approach: the same body shape of a puffer fish, as shown in the video below.



The puffer fish has done more than to show the design that an efficient car could have. It also served as an inspiration for the Bionic Car's structure, which is lighter and yet tougher than that of an equivalent car. According to Mercedes-Benz, the concept weighs a third less than a car of the same size. And it still has a design that, according to the brand, virtually eliminates blind spots. The general reception for the car was not only cold, but also sarcastic. This is probably what steered Mercedes away from even trying to produce something like the Bionic Car. "This is why the marketing departments help you to calculate the weight that emotions play in the purchase of a vehicle. For a carrier, for example, what matters is the cost per km. For a regular customer, many other factors play an influence. And the emotion of having a desirable car weighs in", says Nigro.

Considering that regular drivers have a much bigger share of mileage on the city, at low speeds, than at roads, we could have real bricks over wheels, when it comes to the shape of cars, but it is not only the excitement that plays an important role on

the purchase decision. The client's perception of the vehicle (and of the brand) also requires care. "When we develop a car, we have what we call the city cycle and the road cycle. The city cycle, which is where most of the customers run, has a greater weight. In everyday traffic, people sometimes do not pay attention to consumption, but, on the road, there are few who do not", says the professor. And nobody likes a gas guzzler.



To have a more aerodynamic vehicle, it needs to be born that way. In other words, it has to be designed with this in mind, usually with the help of thousands of hours of wind tunnel. "There are also simpler measures like front grilles that close to allow less air resistance when there is no need for engine cooling, for example", says Nigro.

With the rationale of automobile design and production in mind, which requires millions of calculations and considerations, we can say that we are going to have lighter and more aerodynamic vehicles in the future, with more frugal engines. Not at once, since such calculations of current car manufacturers do not allow for big leaps in the process, as we have explained in this article. Just small steps towards the necessary changes (something that keeps the shareholders happy). When you want a fuel-sipping car, remember the 3 pillars of low fuel consumption. And check which car performs better in all 3 of them.

SHARE  

Related Articles



Latest Articles



Find us on  